

Ausfräsung in der Oberseite / cut out in the top part

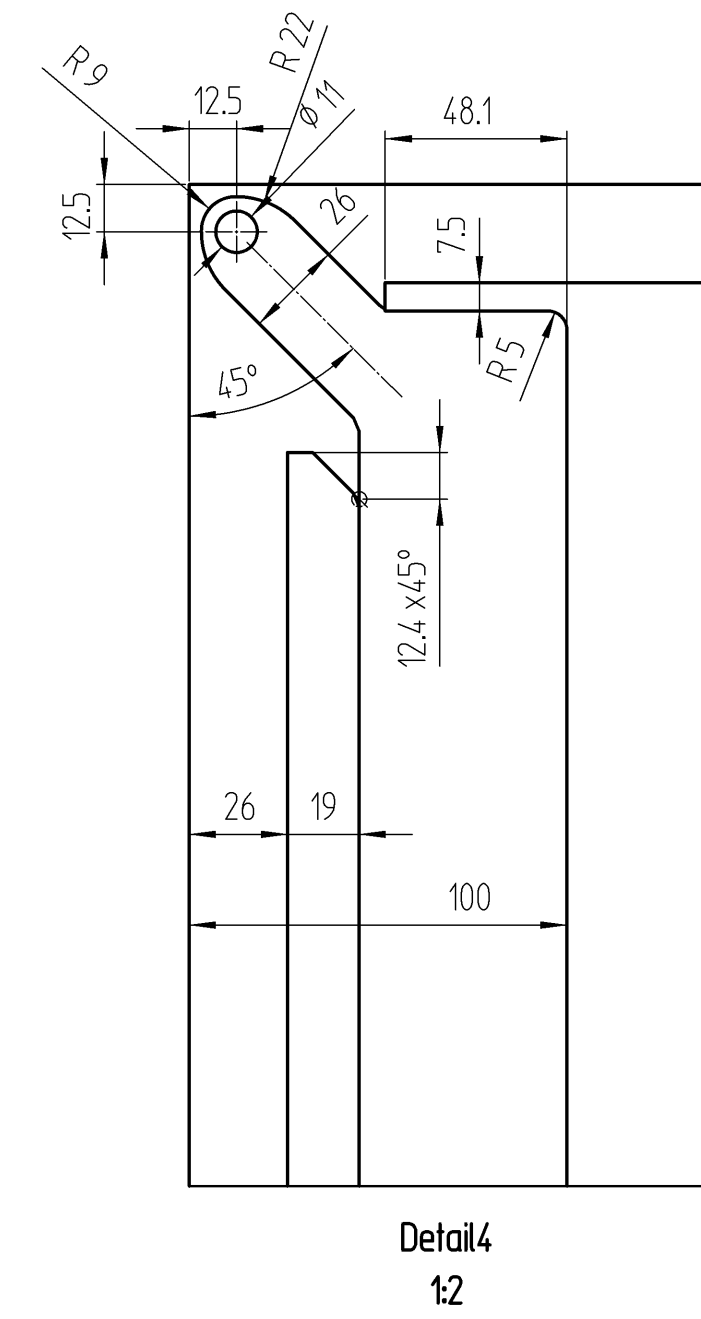

- Zweischaliger Deckel-Aufbau, mit beidseitiger Leuchte / two-part top-construction, with two-sided light.
- Verklebt oder zb. geschraubt im Leuchtenkanal / glued or for example screwed in the light channel.
- Verkabelung und Stecker finden in der Ausfräsung platz / cabling and plugs are in the cut out.

- Deckel kpl. zusammen verleimt / both parts complete glued.
- Elektrifizierung nachträglich möglich / electrification later possible.

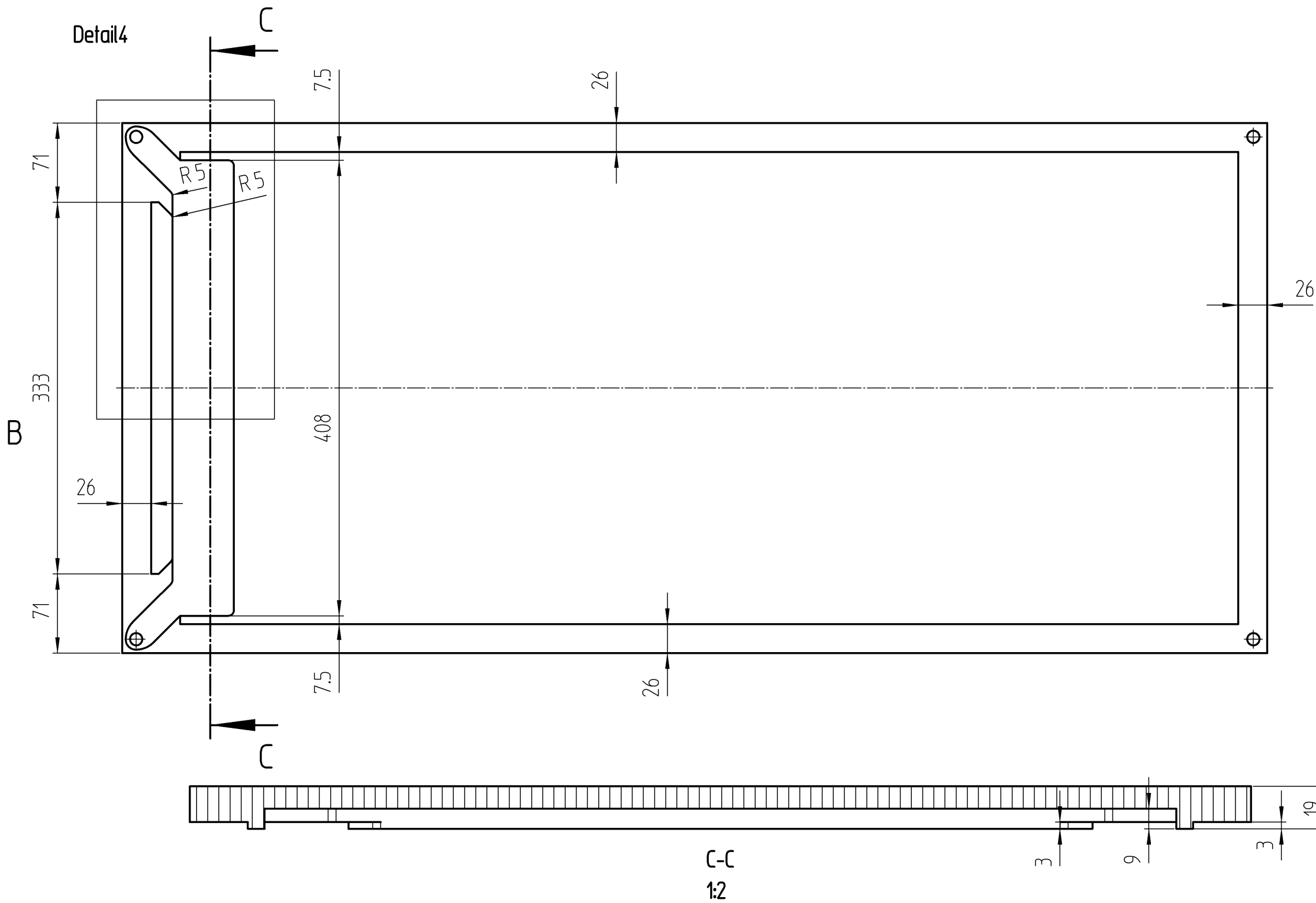
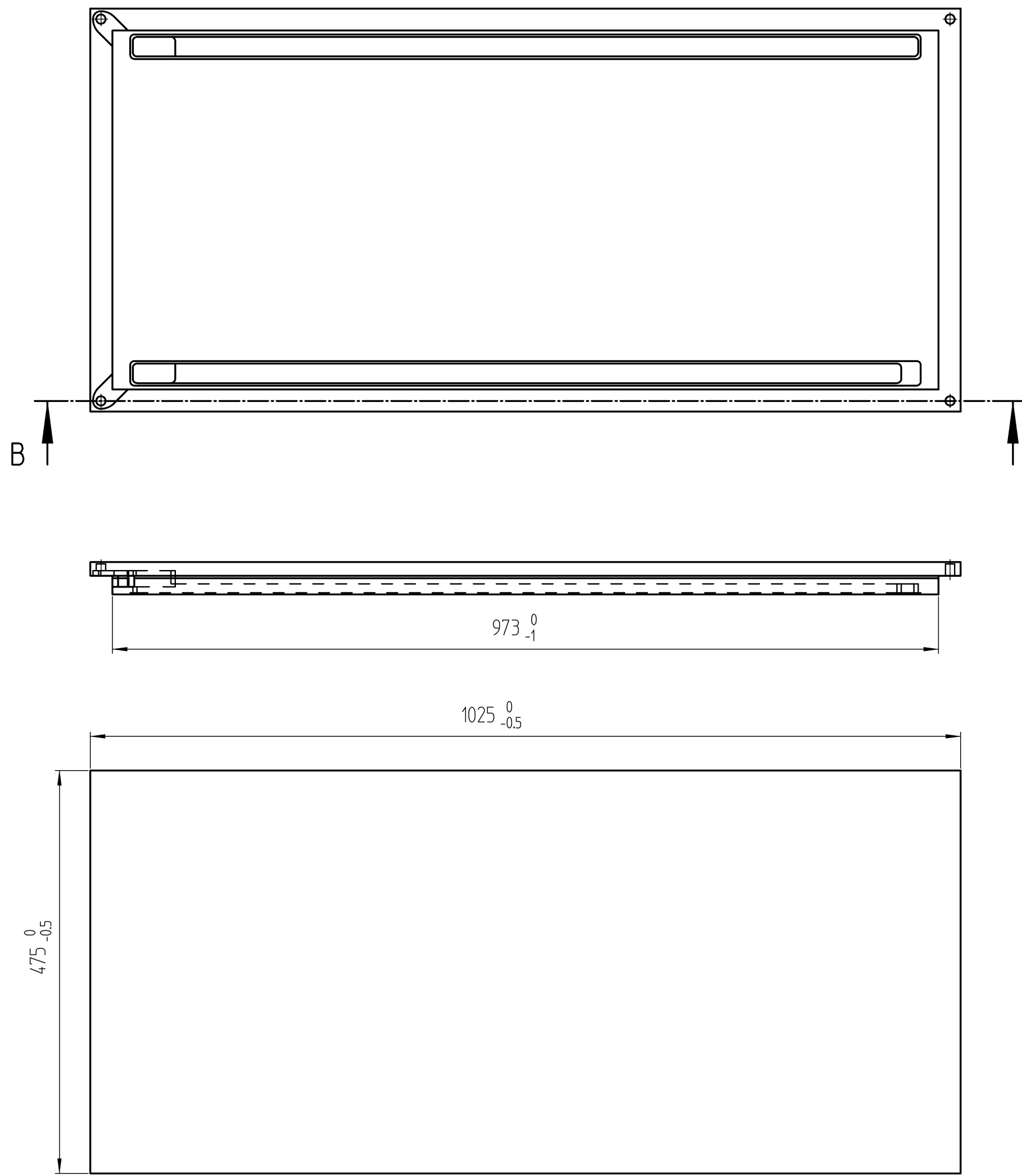
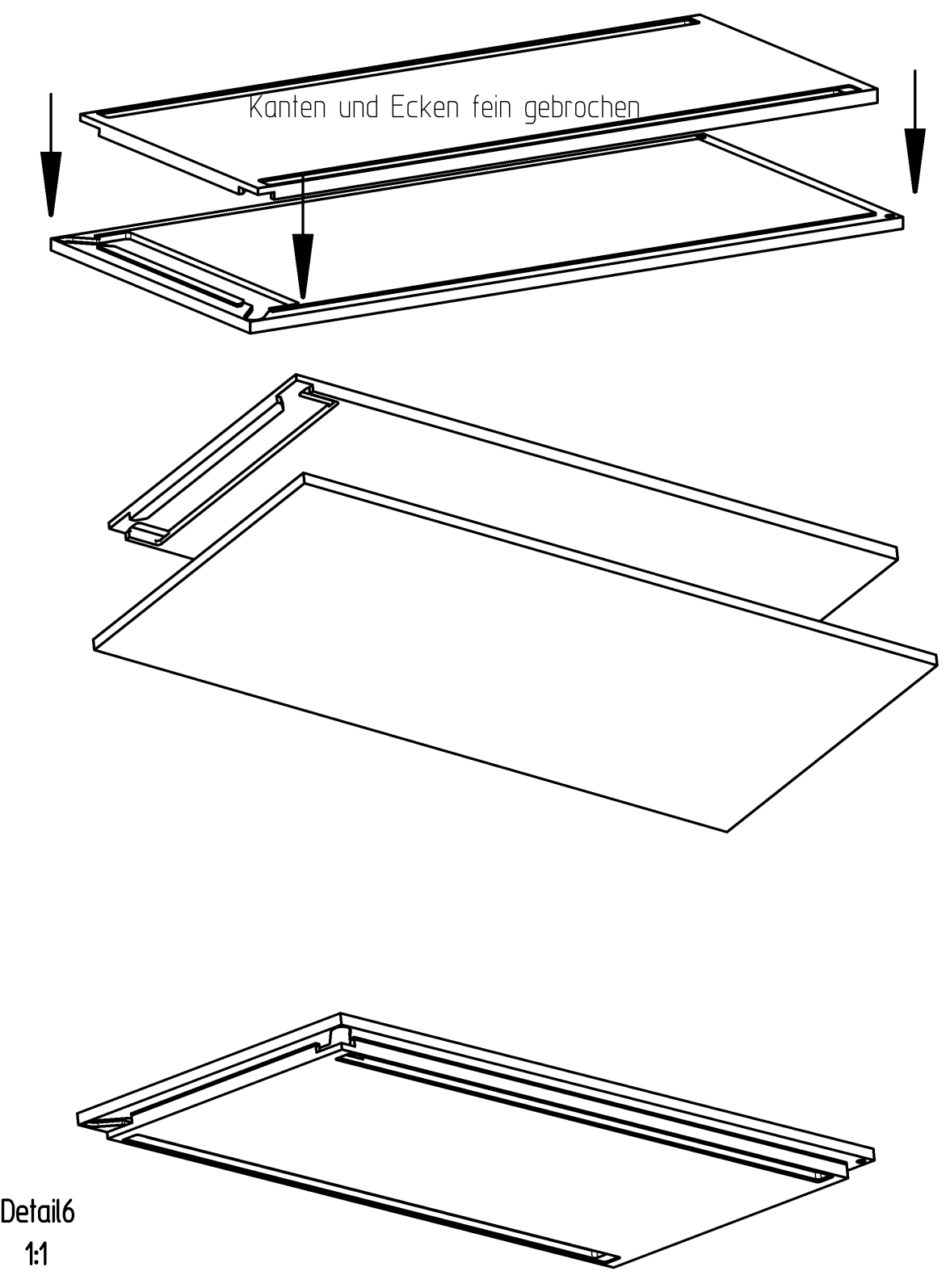

Ausfräsung in der Unterseite / cut out in the bottom part

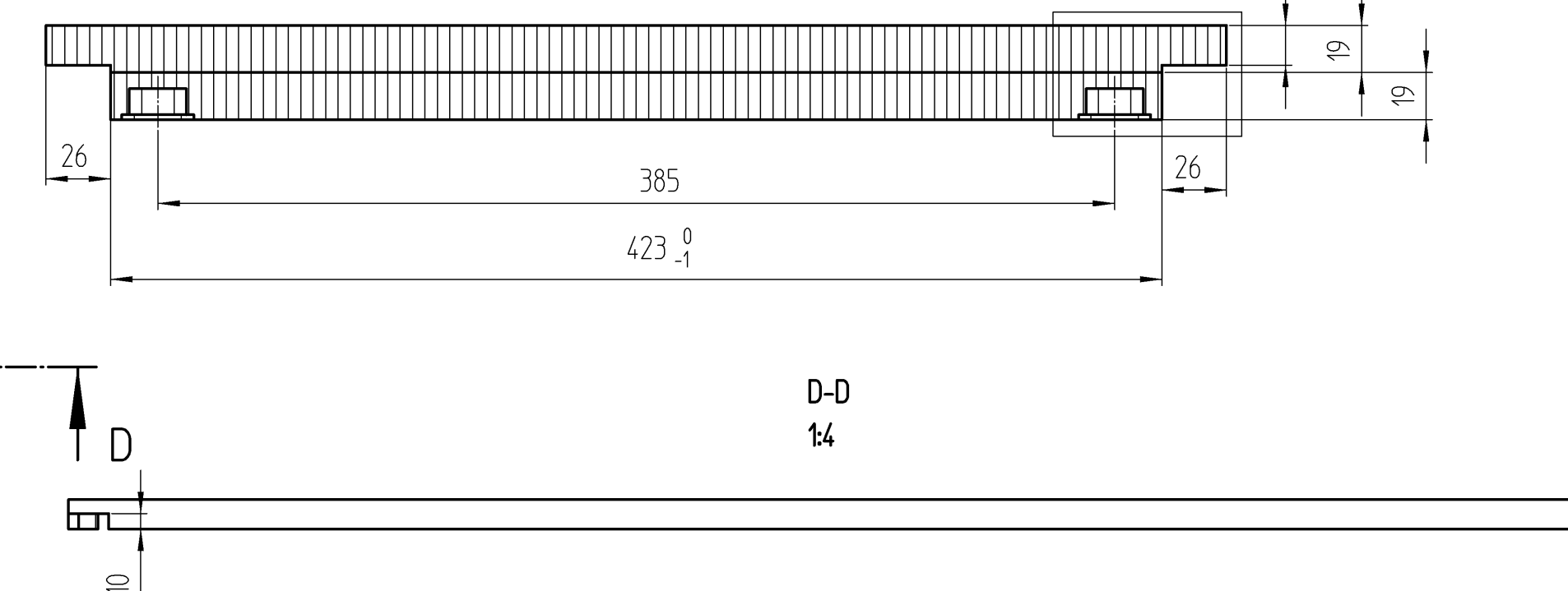
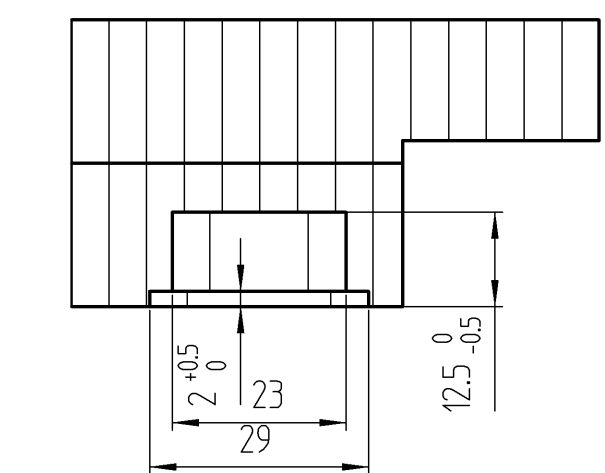
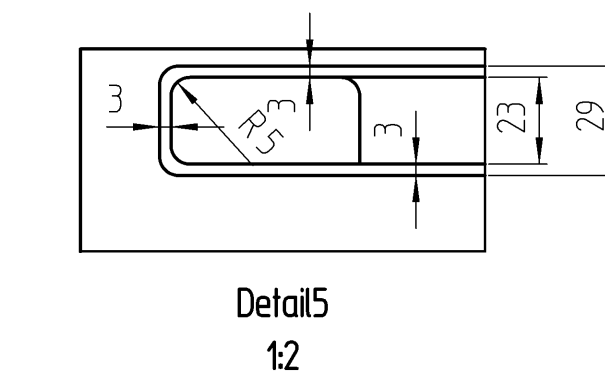
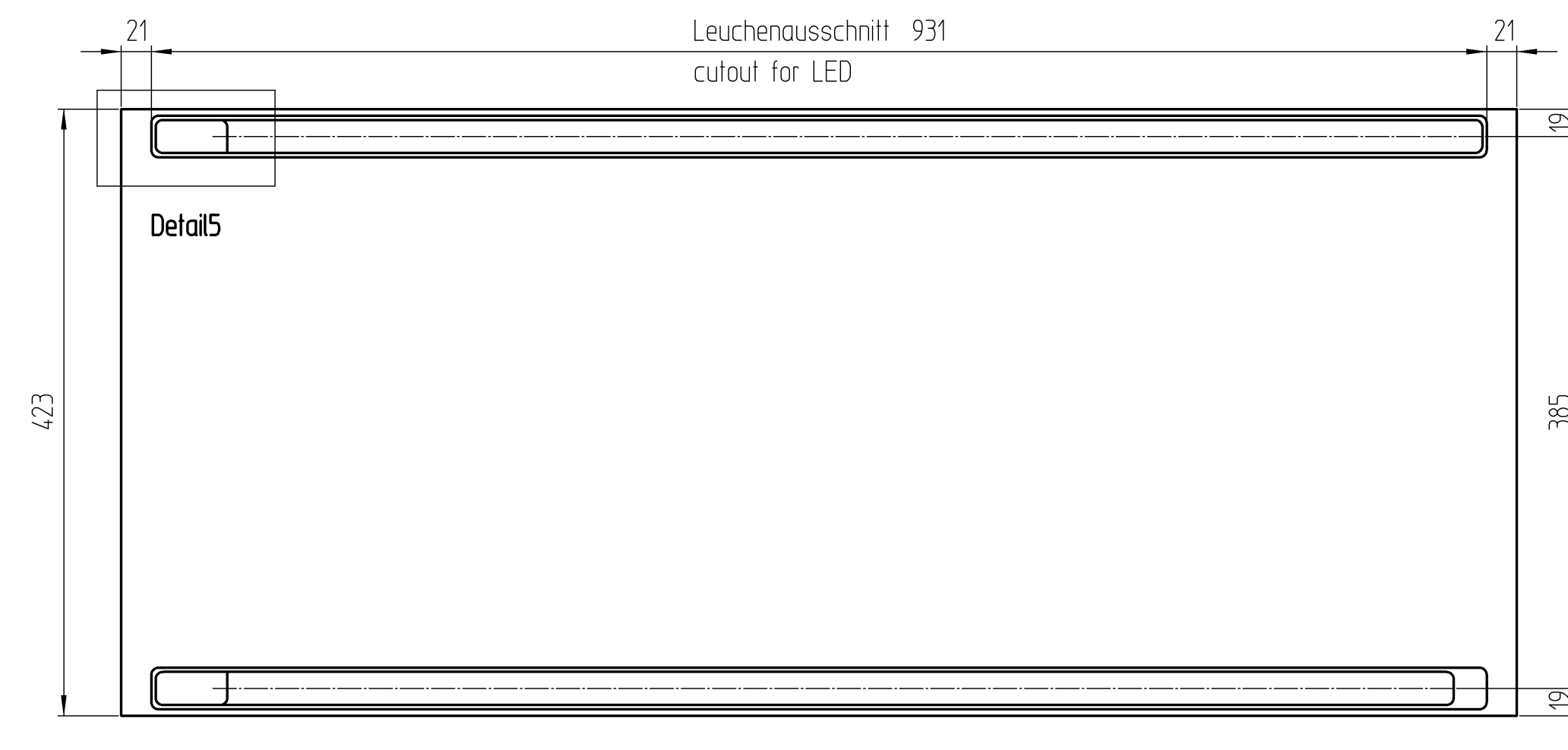

2mm sind einzuhalten, unabhängig von der Dicke der Platte

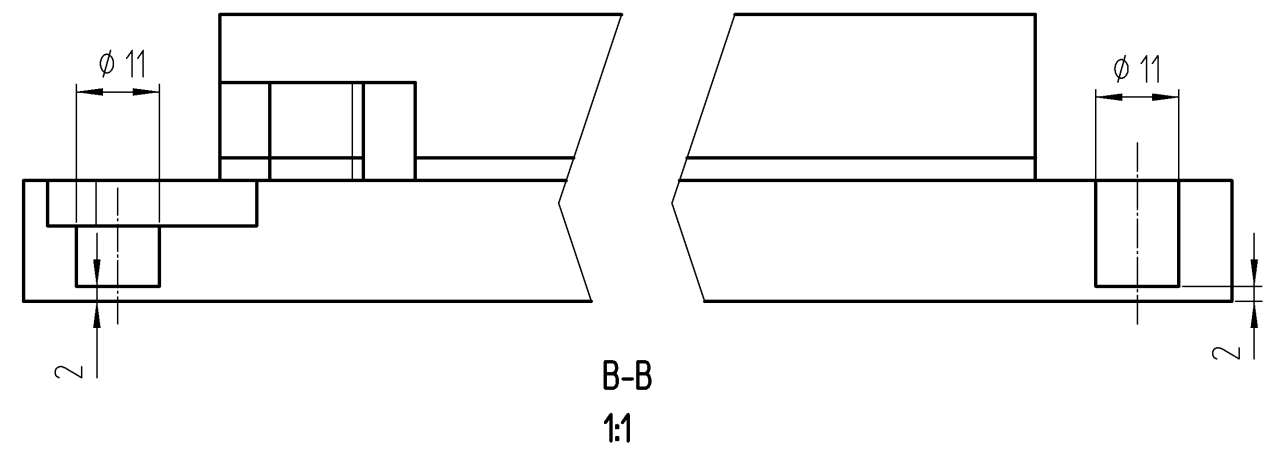

Plattenmaße alle incl. Kanten ringsum mit Kante belegt

Plattenwerkstoff und Oberfläche nach Auftrag

Definierte Schmalseiten mit Kante belegt.

Belegte Kante mit min. Radius R2mm versehen

Piece	Designation/Description	Drawing/Mat.-Nr.	Pos	Material	DIN/VBN	Remark
Changings						
A						
Used by	Date	Name	First used for	Weight/kg	11,873	Foreign designation
Designed	23.07.18	Uecker_M	Free Dim. Tol.	Main Scale		Development No.
Released	03.03.20	Renk_A	ISO 2768-mK	1:5		991-387
In Change						1 A 1/1
Replacement for						
Designation: Abdeckboden einzeln T475/A1000 Leuchten beidseitig						
Project: Customer 991						
www.visplay.com						



Any intellectual property right subsisting in this drawing is owned by our companies. Transferring, using or copying without permission is prohibited.
 Ohne unsere Genehmigung darf diese Zeichnung weder kopiert noch an Dritte Personen weitergegeben werden.